

Current Market Scenario

General Applications

- For use in barns that do not freeze
- For use in barns that do not use highly abrasive bedding (sand)
- For use in barns with even well done cement work.



General product description

Hydraulic Cross Gutter Cleaners

- Gutter up to 61cm (24") wide, standard: 45 cm wide
- Maximum length of 50m (164 feet)
- Requires a hydraulic power unit

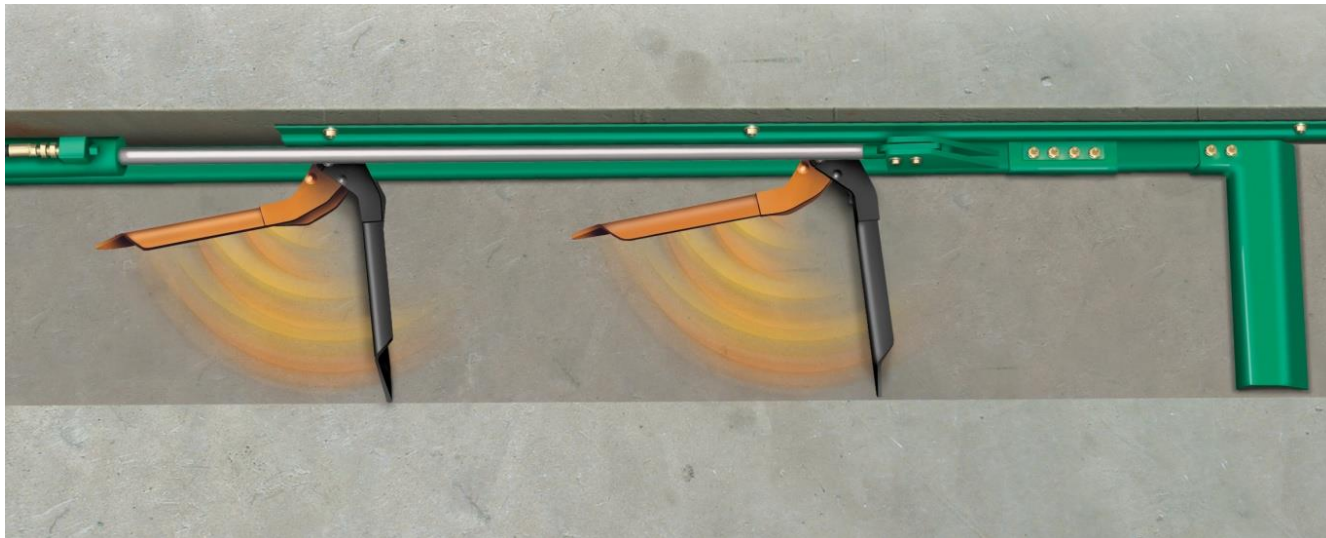

General product description

Hydraulic Cross Gutter Cleaners

Hydraulic Cylinder

Square Rail

Guide



Paddles

General product description

Hydraulic Power Unit



General product description

Steel Box for Hose Outlet

Steel box against gutter for hose outlets

Including 31cm x 18cm (12 3/8" x 7 3/16")
cover plate

Part # 13-76-1182

Designed to be poured in the gutter wall.
The cover plate requires a 1/4" deep recess in
order to be flush with the concrete floor.

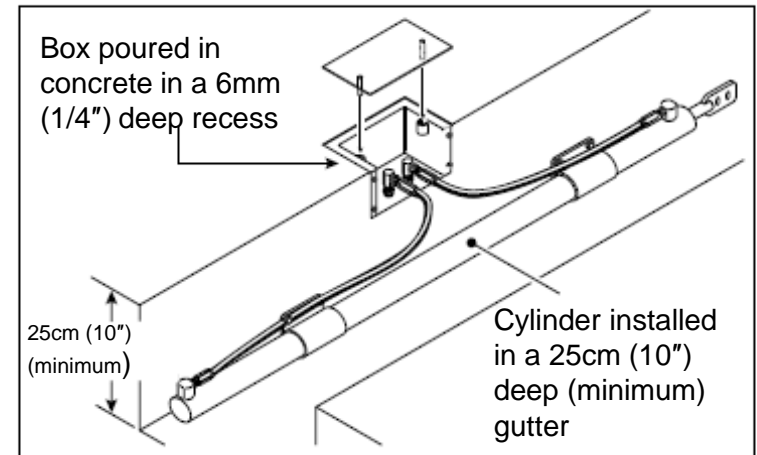
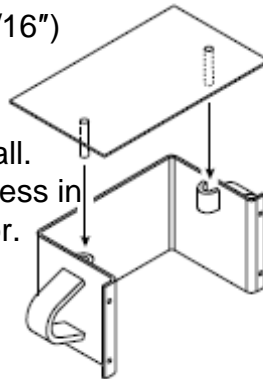

General product description

