

Table of Contents:

Tender Documentation

1. Qualification requirements:	2
2. Terms and place of delivery.....	3
3. Technical specification and requirements for the Goods	3
4. Additional Information about Tender Documentation	4
5. Contact Details	4
6. Draft Agreement No. ____ on Procurement of Goods	5
7. Annex No.1, Price List	10

Tender Documentation

Procurement of Flexible rubber Bags for Transformer for JSC “Georgian State Electrosystem” through Electronic Tender

1. Qualification requirements:

1.1. According to the qualification requirements, the bidder shall submit following documents:

1.1.1. For legal entities of private law and individual entrepreneurs:

- a) An excerpt from Registry of Entrepreneurs and Non-Entrepreneurial (Non-Commercial) Legal Entities;

1.1.2. For legal entities of public law:

- a) A certificate on absence of public and legal restrictions (from the National Agency of Public Registry).

1.1.3. For natural persons:

- a) A certificate on absence of public and legal restrictions (from the National Agency of Public Registry).

1.2. The qualification documents from the administrative authorities, stipulated in paragraph 1.1 of the tender documentation, to be submitted by the bidder (except of non-resident bidder) must be issued after the date of commencement of acceptance of the electronic tender bids.

In case of non-resident bidder he shall submit the qualification documents adequate with documents stipulated in paragraph 1.1. of the tender documentation issued by the duly authorized bodies of his country accompanied by their notarized translations in Georgian. The date of issue of such qualification documents should not be earlier than 30 days prior to commencement of acceptance of the bids.

1.3. The qualification documents to be submitted from the administrative authorities, stipulated by the subparagraph 1.2 hereof shall be submitted within the period requested by the purchaser organization which shall not exceed 5 (five) business days.

1.4. Submission of the qualification documents (copies) from the administrative authorities, by the bidder shall be carried out through system to the procuring organization. The procuring organization shall have the right to demand for submission of the qualification documents from the bidder in the format prescribed by the Georgian legislation by the moment of signing the agreement.

2. Terms and place of Delivery of Goods

- 2.1. Delivery period Flexible rubber Bags for Transformer is no more than 60 calendar days after signing of the agreement.
- 2.2. Place of Delivery of Goods is #29 Kindzmarauli str, Tbilisi, Georgia
 - a. For Nonresident Bidders - GOODS have to be delivered on DAP Georgia, Tbilisi, #29 Kindzmarauli str, Incoterms 2010 condition, according to the Technical Requirements of the Bidding documents.
 - b. For Resident Bidders - GOODS have to be supplied on DDP Georgia, Georgia, Tbilisi, #29 Kindzmarauli str, - Incoterms 2010 condition, according to the Technical Requirements of the Bidding documents.

2.3 The Bidder should submit delivery period of Goods

3. Technical specification and requirements for the Goods

3.1. Technical specification of Flexible rubber Bags for Transformer

Flexible rubber Bags for Transformer Conservator Tank

Protects transformer oil from oxidation and humidity;

Must be made from oil resistant rubber containing flexible material;

Dimensions of Transformer Conservator Tank: length-3900mm, diameter-1570mm

Temperature (resistant): -50+120 C

Detailed dimensions of the Bag are given on the below drawing:

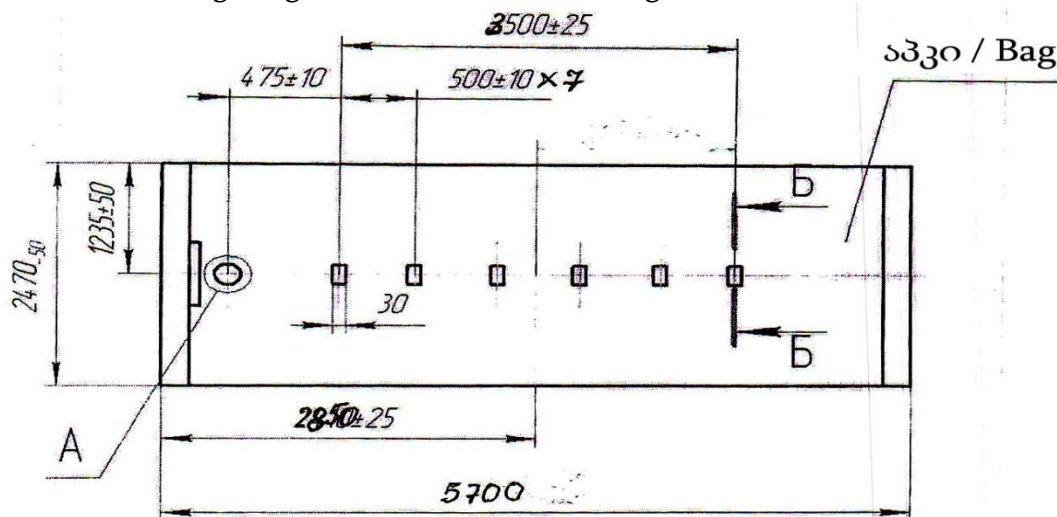

A (1:4)

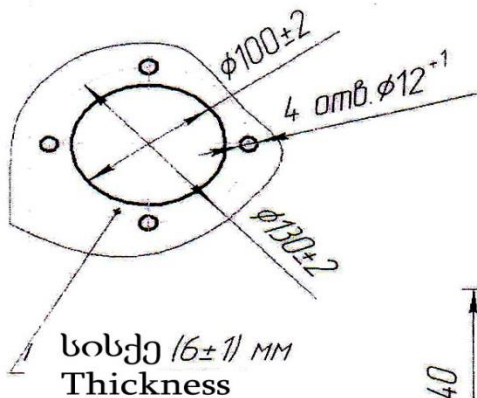

Б-Б

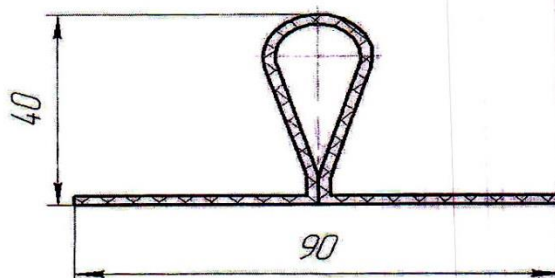

3.2. Requirements.

- 3.2.1 The Bid must be accompanied with Certificates of quality and operating manual;
- 3.2.2 Delivered goods must be accompanied with manufacturers passport;
- 3.2.3. Warranty period for items must be at least 3 years from delivery.

3.2.4 Pricing adequacy justification commitment

In case if the lowest Bidder's final price is 20% or more lower than procurement Estimated cost, within the period defined by the Purchaser, the bidder will be required to justify the pricing adequacy by submitting either the agreement by the Bidder regarding the goods to be supplied and/or invoice and/or bill of lading and/or customs declaration confirming the possibility for the bidder to supply the goods requested by the tender at the offered price (according to subparagraph 12 of paragraph 12 of the Order No 9 of the Chairman of the State Procurement Agency from April 7, 2011 on Approving the Rules for Conducting Simplified Electronic Tender and Electronic Tender). Such document should be issued no more than 6 months before the date of submitting. Documents submitted in foreign language should be appended with Georgian translation duly certified by Notary public.

4. Additional Information on Technical Documentation

- 4.1. Only one winner may be announced in this tender;
- 4.2. **The bid uploaded in the electronic system by the bidder shall include following documents and information:**
 - 4.2.1. Filled-in price list (Annex No.1)
 - 4.2.2. Detailed technical description of the Goods
 - 4.2.3 Certificates of and quality and operating manual;
 - 4.2.4. **Information on requirement of advance payment (at most 30% of the value of the agreement). In case of non-submitting such requirement, it will be believed that the bidder does not require advance payment and the advance payment will not be considered in the agreement.**
 - 4.2.5. **Information about terms of delivery**
 - 4.2.6 **Information whether the Bidder is VAT payer (applicable only if the bidder company is registered in Georgia)**
 - 4.2.7. **Requisites of the bidder: address, identification code, bank requisites, phone or/and fax numbers.**
 - 4.2.8. **Information about warranty terms (at least 3 years from delivery).**
 - 4.2.9. **If requested, the Contract value could be in foreign currency (USD/EUR/Rubles) according to the official exchange rate against GEL, established by the National Bank of Georgia on the day of electronic trading. Such request should be stated in the Bidding Documents.**
- 4.3.
 - a. Nonresident Bidders - GOODS have to be delivered on DAP Georgia, Tbilisi, #29 Kindzmarauli str, - Incoterms 2010 conditions according to the Technical Requirements of the Bidding documents.
 - b. Resident Bidders - GOODS have to be supplied on DDP Georgia, Georgia, Tbilisi, #29 Kindzmarauli str, - Incoterms 2010 conditions according to the Technical Requirements of the Bidding documents.
- 4.4. The means and procedures of demand of additional information and explanation regarding the tender documentation shall be defined in line with the article 6 of the procedure approved by the Order No.9 of the Chairman of the State Procurement Agency, as of April 7, 2011;
- 4.5. **All the mandatory documents shall be submitted in Georgian and/or English and/or Russian language (Documents in English or Russian should be accompanied with Georgian translation duly certified by Notary public).**
- 4.6. The bidder shall have the right to submit only one bid;
- 4.7. Alternative tender bid shall not be allowed.

5. Contact Details

You may receive any additional information and explanations regarding the electronic tender from following members of the tender commission:

Giorgi Tatilashvili - Tel: +995 577779999, E-mail: giorgi.tatilashvili@gse.com.ge

6. Draft Agreement No.____ on Procurement of the Goods

Tbilisi

_____, 2016

I. Parties

- 1.1. The present agreement hereof is made on -----, 2016, by and between JSC “Georgian State Electrosystem”, represented by ----- (hereinafter referred to as the Purchaser), on one hand, and ----- (hereinafter referred to as the Supplier), represented by -----, on the other hand, acting on the basis of the charter of the company and in accordance with the applicable legislation.

II. Subject to the Agreement

- 2.1. The Supplier shall be liable to deliver Goods to the Purchaser (CPV code: 31100000, 31160000) in accordance with the Annex No.1 (price list) and the Annex No.2 (Technical Requirements).
- 2.2. The Annex No.1 and the Annex No.2 are the integral parts of the Agreement hereof.

III. Value of the Goods and Terms and Conditions of Settlement

- 3.1. The total value of the Goods is defined in accordance with the Annex No.1 (price list) hereunder and amounts to --- (-) GEL, ----- VAT (hereinafter referred to as the “Value of the Agreement”).
- 3.2. Settlement shall be carried out according to actually delivered Goods within the period of 10 (ten) calendar days after signing of the delivery-acceptance certificate and submission of the appropriate documentation -----.
- 3.3. If advance payment is required by the Supplier, the Purchaser shall pay to the Supplier the advance amount (at most 30% of the value of the Agreement) in case of submission of the bank guarantee for the appropriate amount by the Supplier, within 5 (five) business days after submission of the bank guarantee
- In case of resident Supplier, the bank guarantee shall be submitted from the bank licensed in Georgia. Validity of the bank guarantee shall exceed the validity of the agreement for at least 30 calendar days.
 - A non-resident Supplier shall submit the bank guarantee confirmed by JSC “Bank of Georgia” (bank code: BAGAGE22). Validity of the bank guarantee shall exceed the validity of the agreement for at least 30 calendar days. The form of the bank guarantee is uploaded in the State Procurement Electronic System together with the bidding documents.
- 3.4. The amount paid in advance shall be considered during final settlement.
- 3.5 Settlement shall be carried out in GEL, by means of the non-cash settlement (via bank transfer).

Note: If required, the Contract value could be in foreign currency (USD/EUR/Rub) according to the official exchange rate against GEL, established by the National Bank of Georgia on the day of electronic trading.

IV. Rights and Liabilities of Parties

- 4.1. The Supplier shall be obliged to deliver Goods (new, unused) to the Purchaser within ____ months from signing the Agreement to the following address #29 Kindzmarauli str, Tbilisi, Georgia
- 4.2. The Supplier shall deliver Goods in accordance with the Annex No.1 (Price list) and the Annex No,2 (Technical Requirements) of this Agreement
- 4.3 The Purchaser shall take the obligation to:
- 4.3.1 Pay the value of the actually delivered Goods to the Supplier in line with the terms and conditions stipulated hereunder.
- 4.3.2 Inspect the condition of Goods;

- 4.3.3 Notify the Supplier in written about defects detected during acceptance or operation of the Goods .
- 4.4. The Supplier shall be obliged to notify the Supplier in writing regarding all the subcontracts concluded hereunder and to present the copies of the agreement concluded with it.
- 4.5. None of the subcontracts concluded hereunder may release the Supplier from material or other obligations. Final relations between the Purchaser and the Supplier shall be carried out according to the terms and conditions of this Agreement.

V. Warranty

- 5.1. The Supplier warrants that the delivered Goods shall be free from any defect in case of compliance with the performance standards.
- 5.2. In terms of appropriate performance, the warrantee period on delivered Goods is – (-) year after starting operation.
- 5.3. If any defect or discrepancy is revealed during the guarantee period, the Supplier shall be liable to correct the defects at its own expenses, within the period of – (-) business days, if correction is impossible the Supplier is liable to replace the goods within the period of – (-) business days after acceptance of written notification from the Purchaser.

VI. Responsibilities of the Parties

- 6.1. In case of delay, incomplete delivery or non-delivery of the goods due to the fault of the Supplier, the Supplier shall be liable to repay the penalty in amount of 0,1% for each calendar day overdue till the day of the delivery of quality goods or termination date of the Agreement, whichever period occurs earlier.
- 6.2. The penalties defined by the paragraph 6.1 of the Agreement hereof shall be accrued for repayment to the Supplier also in case if:
- a) Goods delivered by the Supplier are not accepted due to defects or inaccuracies – from the date of expiration of the term for delivery of goods according to the Agreement till the day of the delivery of goods by the Supplier instead of delivery of defective or inaccurate goods or termination date of the Agreement, whichever period occurs earlier.
- b) The Supplier will not rectify the shortcomings revealed during the guarantee period of the Agreement within the defined term for rectifying deficiencies - from the date of expiration of the defined term for rectifying deficiencies till the day of fully rectifying deficiencies or termination date of the Agreement, whichever period occurs earlier.
- 6.3. In case of delay (delayed) of payment by the Purchaser the Supplier may request the Purchaser payment 0,1% of the unpaid amount for each day of delay till the termination date of the Agreement or fully payment day, whichever period occurs earlier.
- 6.4. In case of unilateral non-implementation of the liabilities imposed hereunder, the parties are liable to compensate the caused damage in full according to the rule set by the applicable legislation of Georgia. Compensation of the damage or its demand does not stop accrual of the penalties stipulated by the article hereof.
- 6.5. The Purchaser is authorized to deduct (to reduce payment by) accrued penalties and fines envisaged by this article and charged to the Supplier during payment of price of actually delivery goods. This deduction cannot be mentioned as a basis of penalty from the Supplier to the Purchaser according to the paragraph 6.3.

VII. Control over Implementation of the Agreement

- 7.1. The Purchaser or his representative has the right to implement control over the fulfillment of the

Supplier's obligations at any stage of the Agreement.

- 7.2. The Supplier shall be obliged to correct all the defects or faults revealed after such control at its own expense.
- 7.3. The control over implementation of the Agreement by the Purchaser is carried out by _____ — of JSC “Georgian State Electrosystem”.
- 7.4. The control is carried out through compliance of the quality and delivery terms of the Goods with the terms and the conditions of the Agreement.

VIII. Force-Majeure

- 8.1. Suspension of the terms and conditions of the Agreement or any of them due to incurring of the force-majeure circumstances shall not be considered as non-implementation or violation of the terms and conditions of the Agreement hereof and will not cause imposing of the penalty sanctions.
- 8.2. For the purposes of the article hereof, “Force-Majeure” means the circumstances insuperable for the parties and beyond their control or independent from the parties, which are not related to their errors and negligence and which bear the preliminarily unforeseen character. Such circumstances might be caused due to war or natural calamities, epidemic, quarantine, imposing of embargo, etc. For sufficient certificate confirming existence of force-majeure, the parties agree upon to consider the appropriate certificate issued by the Chamber of Commerce and Industry of the relevant country.
- 8.3. In case of incurring of force-majeure circumstances, the contractual party, for which it becomes impossible to implement the undertaken liabilities, shall immediately send to the other party the written notification regarding such circumstances or their reasons. If the party sending the notification does not receive the written response from the other party, such party at its discretion, according to the appropriateness and the own capabilities continues to implement the liabilities undertaken due to the Agreement hereof and tries to find out such alternative ways for implementation of the liabilities, which would be independent from impact of the force-majeure circumstances.

IX. Relations between the Parties

- 9.1. Any official relations between the contractual parties shall be implemented in writing. The written notification, which the party sends to the other in accordance with the Agreement, shall be sent in form of the mail notification or email correspondence by the person authorized for management and/or representation or by people authorized in terms of the Agreement as a contact persons (for email correspondence) . With the purpose to set the immediate and efficient contact, it is possible to send the notifications via e-mail (scanned version of the letter) or fax, with the conditions to deliver the original lately.
- 9.2. The notification enters into force on the day of its receipt by the addressee or the date set for validation of the notification, whichever incurs later.

X. Modification of the Terms and Conditions of the Agreement and/or early Termination

- 10.1. Any modification and/or amendment to the Agreement hereof might be carried out on the basis of the written agreement by and between the parties.
- 10.2. Modification of the terms and conditions of the procurement agreement is inadmissible, if as the result of such modifications the total value of the Agreement increases or the terms and conditions of the Agreement for the procuring entity are deteriorated, except for the cases stipulated by the Article 398 of the Civil Code of Georgia. Besides, the total value of the Agreement shall not increase by more than 10%.

- 10.3. The agreement might be terminated preliminarily in the following cases:
 - 10.3.1. Upon agreement of the parties;
 - 10.3.2. With the statement of one of the parties in case of substantial violation of the terms and conditions of the Agreement hereof by the other party;
- 10.4. The Purchaser may terminate the agreement preliminarily in the following cases:
 - 10.4.1. If it becomes known to the Purchaser that due to the reasons beyond the control of the latter, the Purchaser fails to provide implementation of the liabilities imposed hereof;
 - 10.4.2. In case of bankruptcy of the Supplier;
 - 11.4.3. If it becomes known to the Purchaser that the information submitted by the Supplier is false which is the basis for losing of confidence of the Purchaser.
 - 10.4.4. In other cases as stipulated by the applicable legislation of Georgia.
- 10.5. In the cases indicated in the paragraph 10.4 hereof, the Purchaser is obliged to compensate the value of the actually delivered Goods to the Supplier.

XI. Interfering to Implementation of the Agreement

- 11.1. If during the process of implementation of the Agreement the parties face any impeding circumstances, due to which implementation of the terms and conditions of the Agreement is interfered, such party shall immediately send to the other party the written notification on fact of interfering, its possible duration and the reasons. The party receiving the notification shall communicate own decision made regarding the indicated circumstances to the other party as soon as possible.
- 11.2. In the event if due to interfering to implementation of the terms and conditions of the Agreement the parties agree upon to prolong the term for implementation of the terms and conditions of the agreement, such decision shall be concluded by means of introducing of the modifications into the Agreement.

XII. Settlement of Dispute

- 12.1. The contractual parties hereby agree upon to refer to all the efforts in order to settle all the disputes and the discrepancies incurred by and between the parties regarding the Agreement or the issues related to the Agreement via amicable negotiations,.
- 12.2. If in the term of 30 (thirty) days after commencement of such negotiations the parties fail to agree upon the disputable issues, any party is entitled to solve the dispute by applying to the Georgian court according to the set rule. The dispute will be settled according Georgian legislation

XIII. Delivery-Acceptance Procedure of Purchase Object

- 13.1. The delivery-acceptance certificates shall be concluded on the actually delivered Goods .
- 13.2. The person(s) defined by the Purchaser according to the subparagraph 7.3 hereunder shall check the compliance of the delivered Goods with the terms and conditions of this Agreement. In case of absence of defect, the delivery-acceptance certificate shall be concluded on the actually delivered Goods .
- 13.3. While acceptance of the Goods , in case of reveal of any fault (defect), the Purchaser shall be liable to notify the Supplier regarding the relevant faults (defects) immediately and in the effective manner in writing.
- 13.4. In case of revealing the faults (defects), the Supplier is liable to correct the defect within the period of – (–) business days at its own expenses, if correction is impossible the Supplier is liable to replace the goods within the period of – (–) business days.

13.5. The Goods shall be considered as accepted upon signing of the delivery-acceptance certificate by and between the parties. After signing the delivery-acceptance certificate responsibility for the Goods is transferred to the Purchaser.

XIV. Validity of the Agreement

- 14.1. This Agreement enters into force upon its signing by the parties.
- 14.2. The validity of this Agreement shall be considered as expired upon fulfillment of the above terms and conditions, nevertheless **no later than** _____ **201-**, and in the part of the warrantee obligations – until the end of the warrantee validity.

XV. Miscellaneous

- 15.1. The Agreement is drafted in Georgian and/or English language in two copies and each of them bears equal legal force.
- 15.2. In the cases not stipulated hereunder, the parties shall act in accordance with the applicable legislation of Georgia.
- 15.3. The terms and conditions stipulated by the Agreement hereof are binding and obligatory for implementation by the parties and their legal successors and assignees. It is inadmissible to assign the liabilities foreseen by the Agreement hereof to the other party without preliminary written consent by the other party.
- 15.4. The terms and conditions stipulated by the Agreement hereof, Information about the Tool, information submitted to the “Supplier” by the “Purchaser” and/or any other information exchanged between parties during the supply of the services are the confidential information and shall not be disclosed to the other party, except for the cases prescribed by the legislation.
- 15.5. The Agreement hereof is drawn in accordance to the subparagraph (p), paragraph first, article 3 of the Law of Georgia on State Procurement.

XVI. Requisites of the Parties

Purchaser

Supplier:

Annex No.1
Price list

Annex No.2
Technical Requirements

7. Annex No.1,

Price List

Procurement of Flexible rubber Bags for Transformer for JSC “Georgian State Electrosystem”

The Bidder shall fill below table

The bidding price shall be given in GEL, without VAT

Name of the bidder: _____

Nº	Description of Goods	unit	q-ty	Country of origin	Manufacturer	Unit price GEL	Total price GEL
1	2	3	4	5	6	7	8
1	Flexible rubber Bags for Transformer	pc	5				

Note:

1. Value of the bid shall include all the expenses.

Signature of bidder: _____

Seal